

SECTION D-D
SCALE 2/1

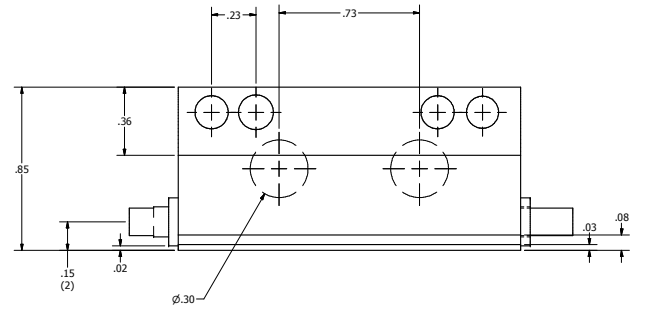

DRAWN jbelliz	11/18/2013	NCACP Engineering
CHECKED		TITLE
QA		Front Auto block
MFG		
APPROVED		SIZE DWG NO REV
		D Car with dimintions
		SCALE SHEET 1 OF 6

4 3 2 1

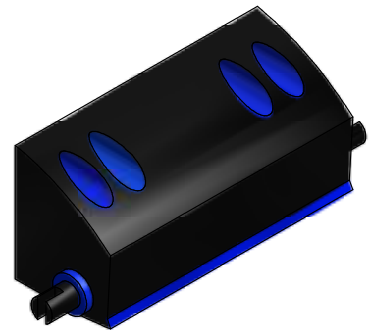
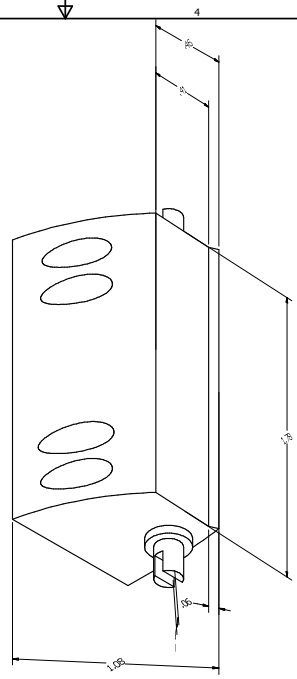
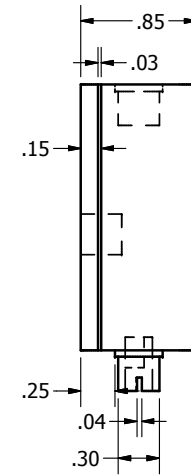
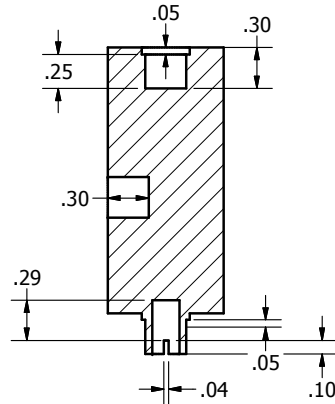
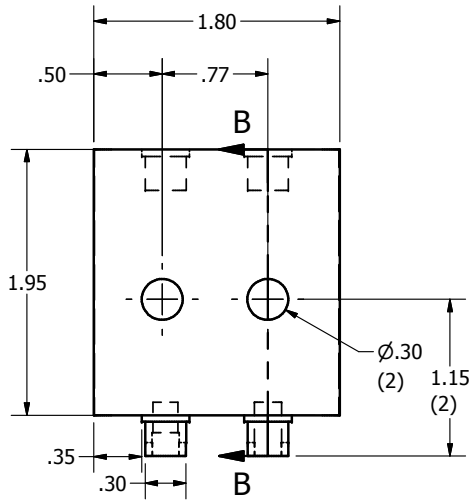
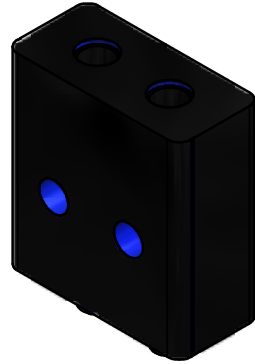
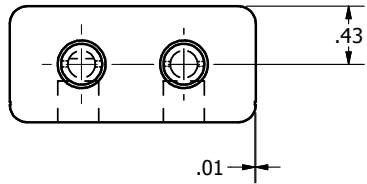

SECTION B-B
SCALE 1.1

DRAWN jbell2	11/18/2013	New castle career center		
CHECKED		TITLE		
QA		Middle Auto block		
MFG				
APPROVED				
		SIZE B	DWG NO	REV
			Car with dimintions	
		SCALE	SHEET 2 OF 6	

4 3 2 1

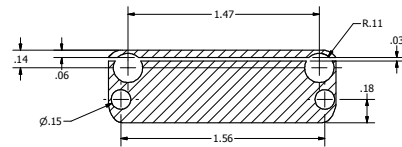
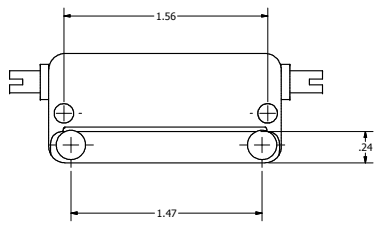

SECTION A-A
SCALE 2.1

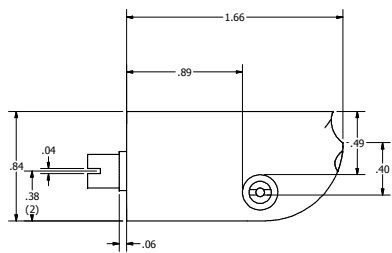
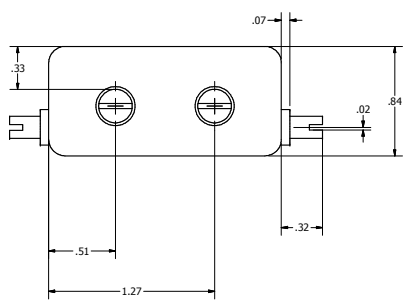
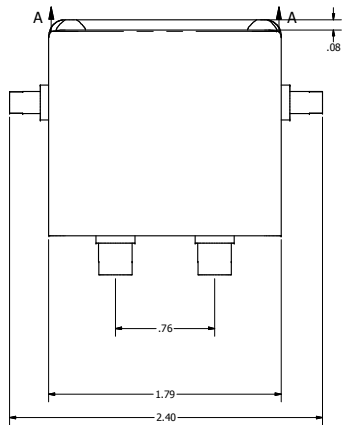

DRAWN	11/18/2013	TITLE	
CHECKED		New Castle carree center	
QA		Back view	
MFG		SIZE	DWG NO
APPROVED		D	Car with dimintions
		SCALE	REV
			1

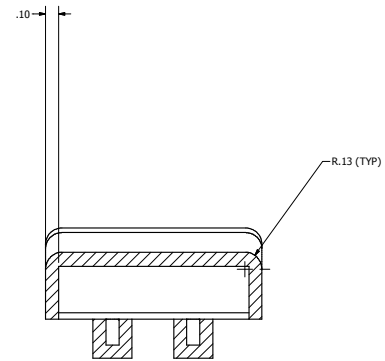
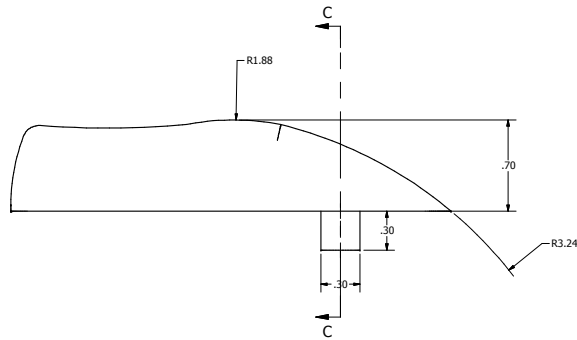
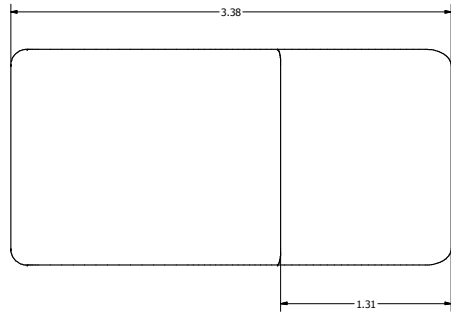

SECTION C-C
SCALE 2.1

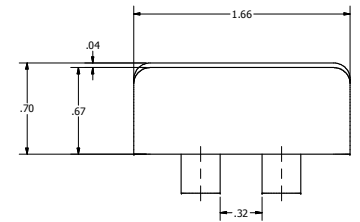

DRAWN jbe12	11/18/2013	NCACP Engineering	
CHECKED		TITLE	
QA		Top Auto block	
MFG			
APPROVED		SIZE D	DWG NO
		SCALE	Car with dimintions
			REV

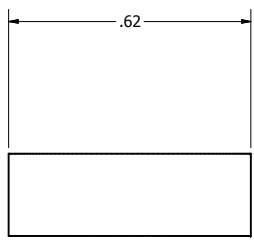
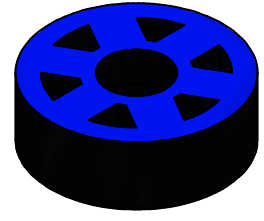
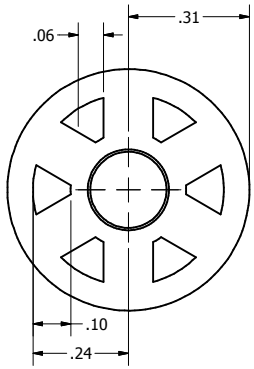

DRAWN	jbell2	11/18/2013			
CHECKED			TITLE		
QA					
MFG					
APPROVED					
			SIZE	DWG NO	REV
			C	Car with dimintions	
			SCALE	SHEET 5 OF 6	

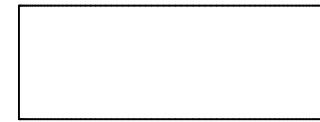
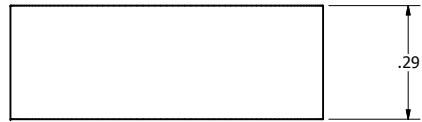
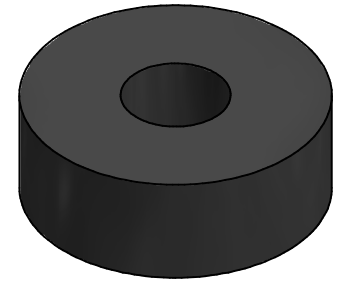
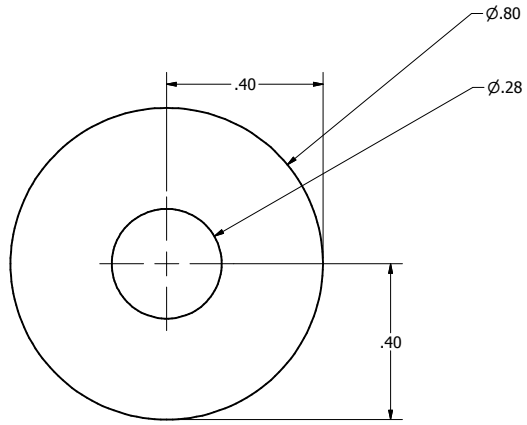

DRAWN	11/18/2013	NCACP Engineering		
CHECKED		TITLE		
QA		Tire Auto block		
MFG		SIZE	DWG NO	REV
APPROVED		C	Car with dimintions	
		SCALE	SHEET 6 OF 6	